



<http://wiki.homerecz.com>

.....	1
.....	1
.....	1
.....	1
TUBE-TECH MP1A	5
1.	5
2.	5
3.	6
Schematic	6
.....	8
.....	8
.....	8
.....	8

TUBE-TECH MP1A

TUBE-TECH MP1A
A)

Lydkraft

(Class

1.

- : (Class A)
- :
 1. Class A
 - 2.
- :
 1. +70dB ()
 2. +30dB ()
- :
 1. : XLR ()
 2. : XLR
- :
 1. 5Hz ~ 60kHz (+/-0.5dB)
- THD():
 1. 80dB @70dB
- : AC (115V/230V 가)
- :
 1. : 19 (2U)
 2. : 6~8kg¹⁾.

2.

- Class A :
 - 1.
 - 2.
- :
 - 1.
 2. (48V) 가 .
- :
 1. , (-20dB), , 가 .
- :
 - 1.

2.

3.

TUBE-TECH MP1A

가

, TUBE-TECH

가

- Tube based push-pull output amplifier
- Gain from +20dB to +70dB in 5dB increments
- Pad in front of input transformer (-20dB)
- Built-in +48V phantom power
- Microphone input impedance = 1.2kΩ
- CMRR >60dB@10kHz
- Direct Instrument Jack-socket input for various instruments
- DI input impedance > 1MΩ
- Frequency Response @ -3dB: 5Hz to 60kHz
- Typical noise figure: 5dB@200 Ω



Schematic

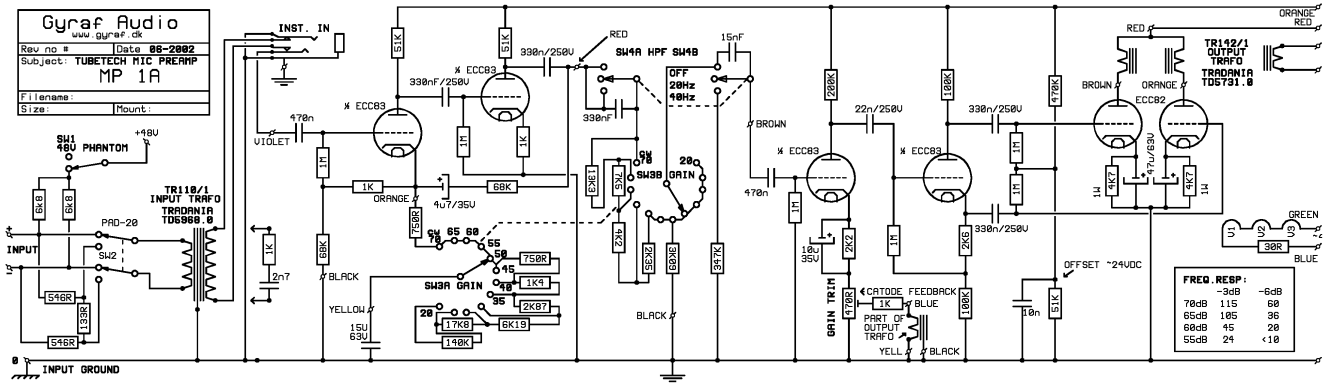

1)

<https://www.tube-tech.com/>



<http://wiki.homerecz.com>

From:

<https://wiki.homerecz.com/> -

Last update: **2025/03/20**

: (admin@homerecz.com)