



<http://wiki.homerecz.com>



---

.....	1
.....	1
.....	1
.....	1
.....	5
<b>IEC 60318-4(IEC 60711)</b> .....	5
<b>HATS(Head and Torso Simulator)</b> .....	7
<b>AP AECM206 Bianural fixture</b> .....	8
<b>HATS+</b> .....	9
.....	10
Ear Resonance .....	11
<b>Target</b> .....	11
.....	12
.....	12
.....	13
Target Compensated Frequency Response .....	14
<b>HD600</b> .....	14
<b>Reference</b> .....	16
.....	17
.....	17
.....	17
.....	17



- a) Circumaural
- b) Supra-aural
- c) intra concha
- d) insert

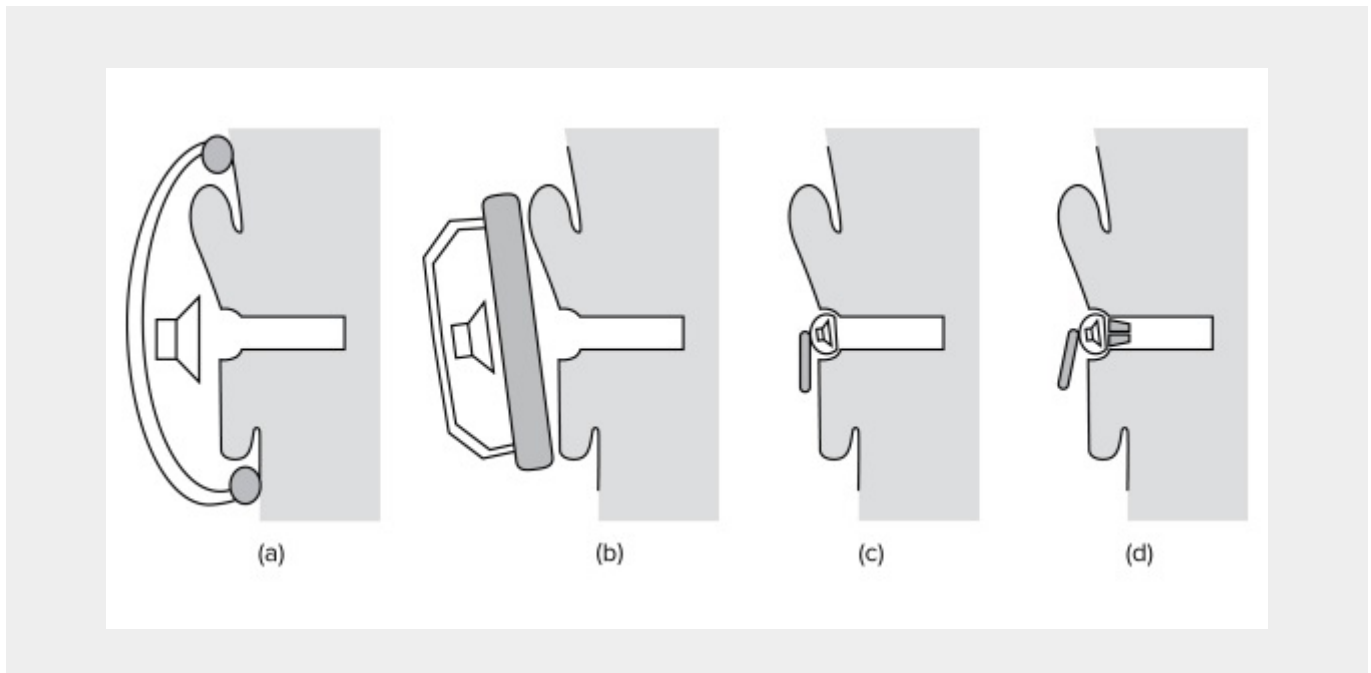

**DRP(Drum Reference Point)**

가

HATS

1mW

94dB SPL@500Hz

## IEC 60318-4(IEC 60711)



IEC( )      )      DRP( ,  
)      가      .  
Ear Canal Extension ,



# HATS(Head and Torso Simulator)



HATS

, 가





## AP AECM206 Binaural fixture

HATS , Audio precision AECM206 .







# HATS+

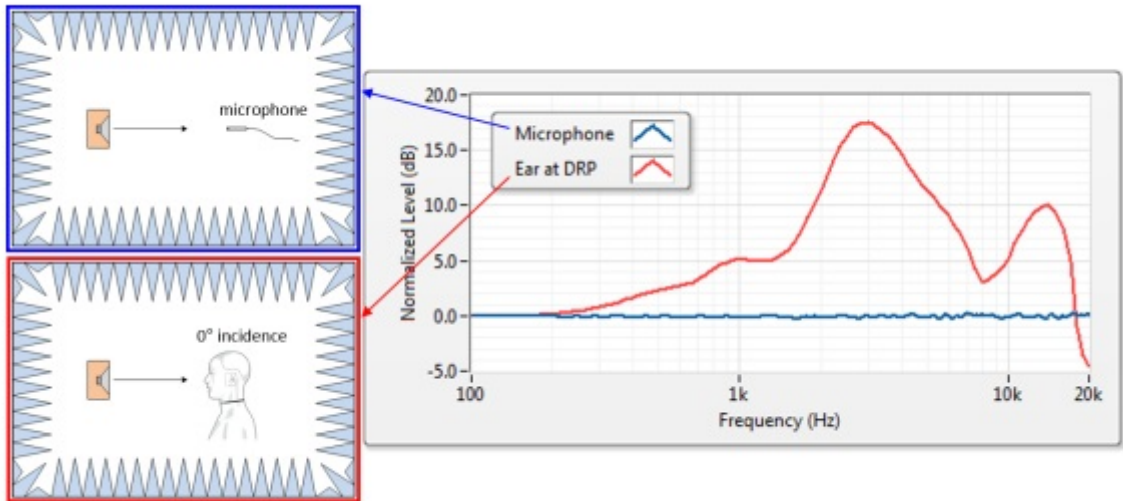

, HATS

가

Ear Response 3kHz HRTF( 15kHz )

가  
가

가

가

### Influences on measured ear resonance

45° angle of incidence

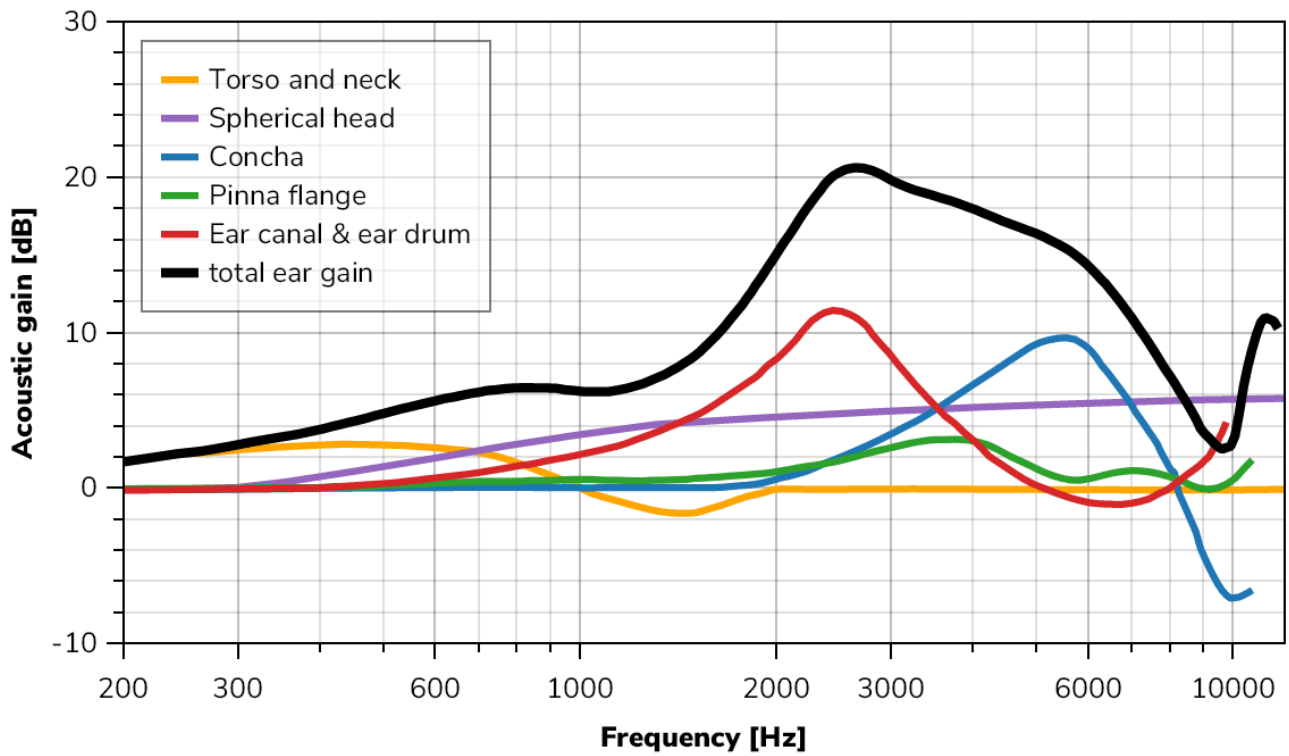

- 1.
- 2.
3. ( )
4. ( )
- 5.
- 6.

# Ear Resonance

Ear resonance is a term that refers to the phenomenon where the human ear resonates at specific frequencies, resulting in certain frequencies being perceived or detected more strongly than others among the sounds entering the ear. This phenomenon depends on the structure and characteristics of the ear as well as the individual's unique physiological traits.

Ear resonance is primarily an important consideration in the fields of audio engineering and sound design. For example, when designing speakers or headphones, ear resonance at specific frequency ranges can occur, potentially emphasizing or distorting sounds within those frequency ranges. Therefore, it is essential to take this phenomenon into account when designing and tuning audio equipment.

Ear resonance can vary from person to person based on the shape and characteristics of their ears and tends to occur predominantly in the high-frequency range. These resonance frequencies are a crucial variable that audio technicians and sound designers need to consider when adjusting and tuning audio systems.

## Target

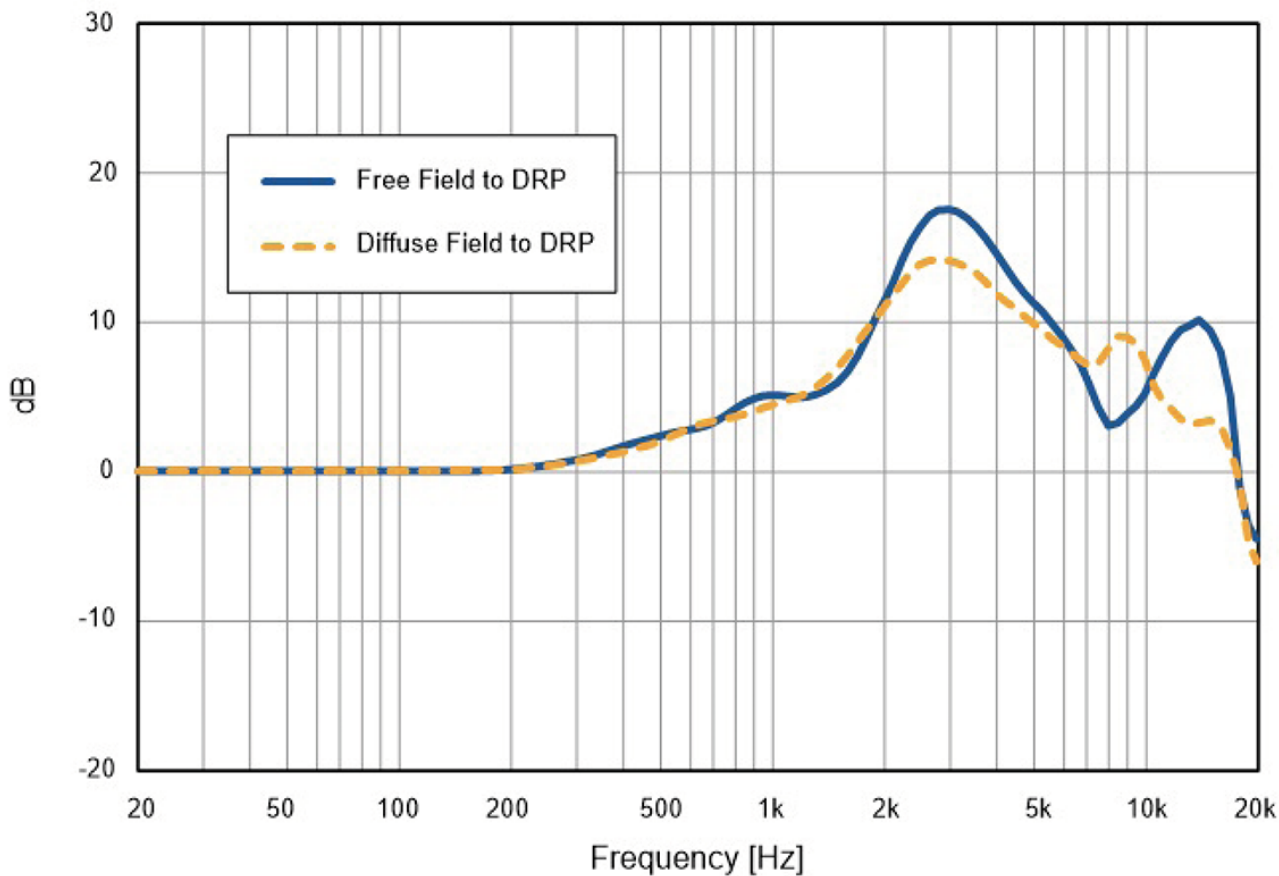

Free-field      diffuse field      가      .

4가

가

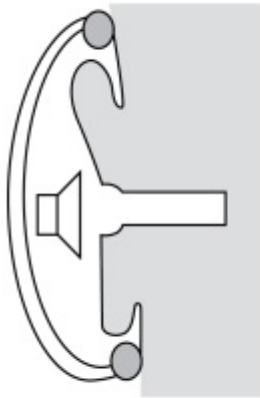

(a)

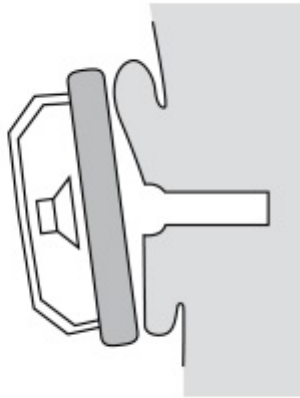

(b)

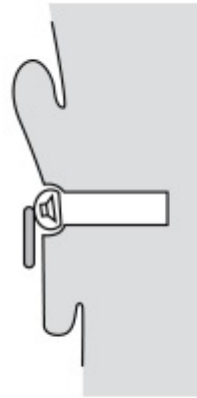

(c)

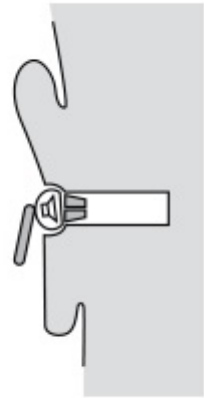

(d)

Free-field target

diffuse field target

Free-field

가

가

diffuse field

가

가

(Harman International)

가

- 가 :
- :
- :
- :

- : 가
- : 가
- : EQ( )

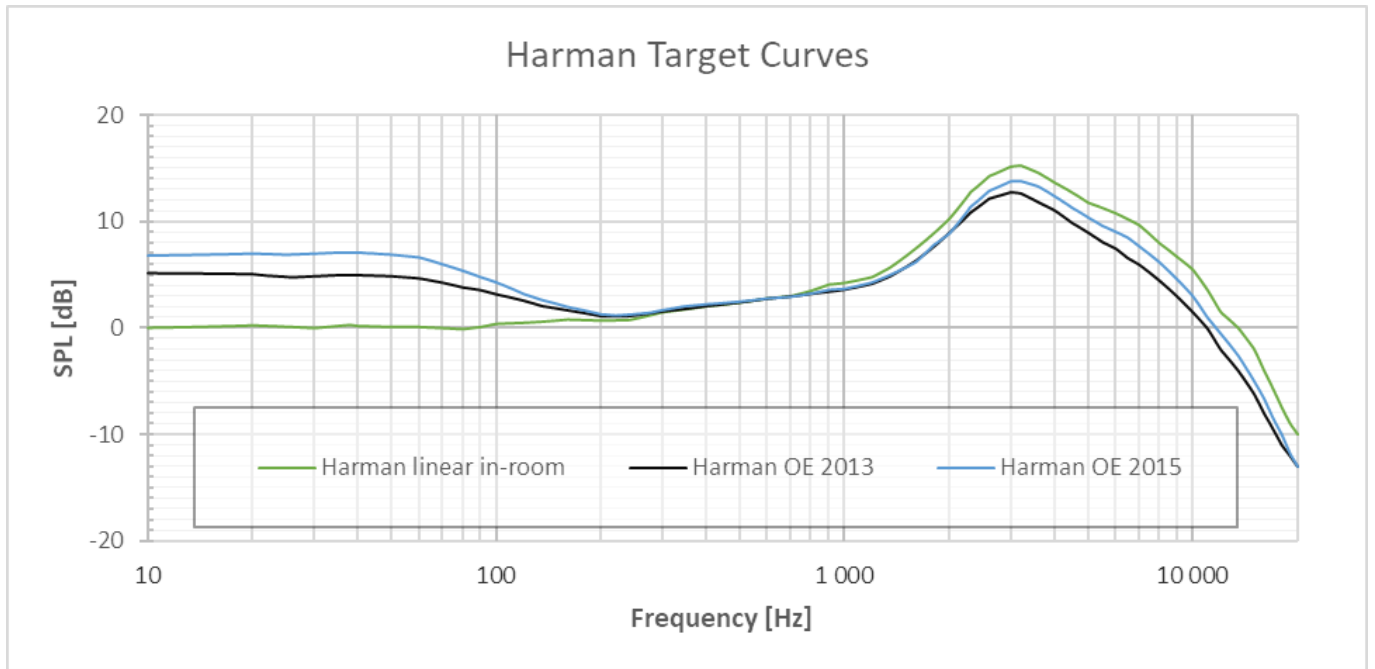

- OE : Over Ear target
- IE : In-Ear Target

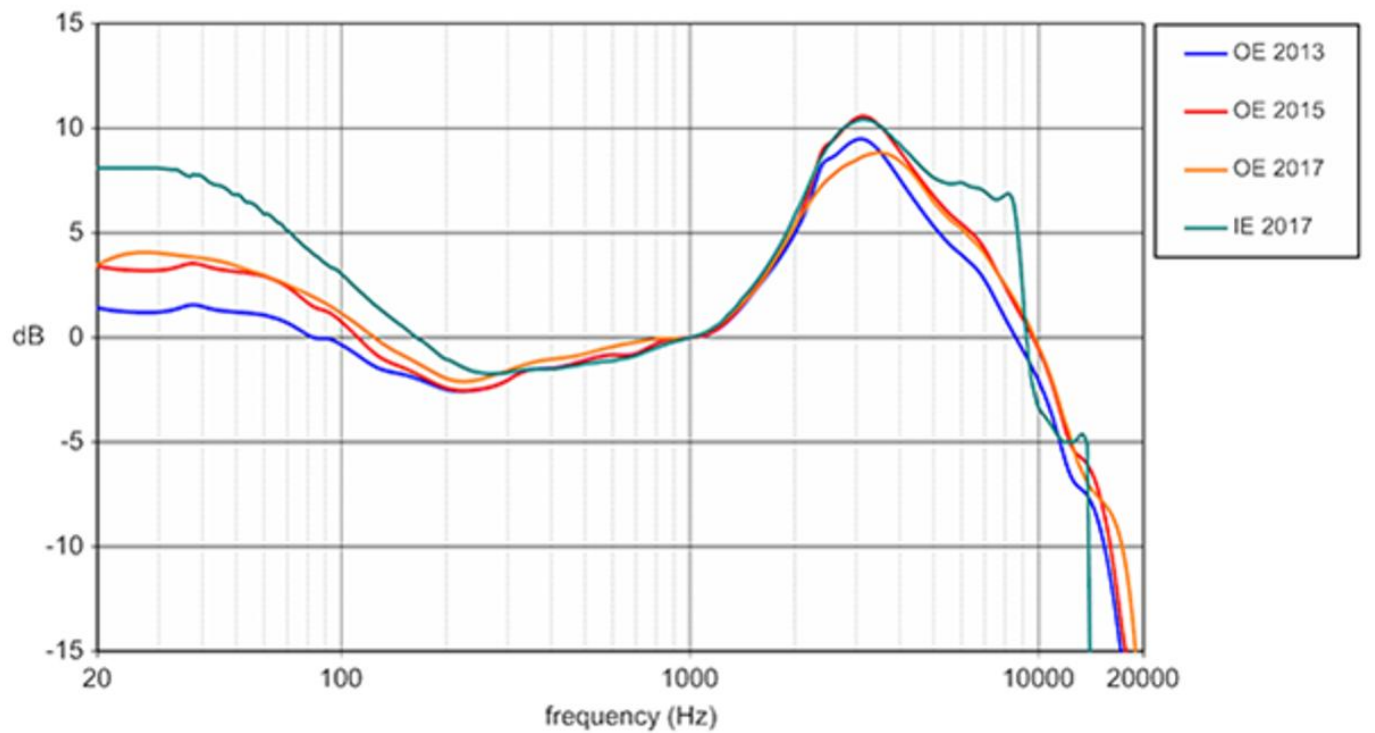

# Target Compensated Frequency Response

Diffuse Target , Target

Target

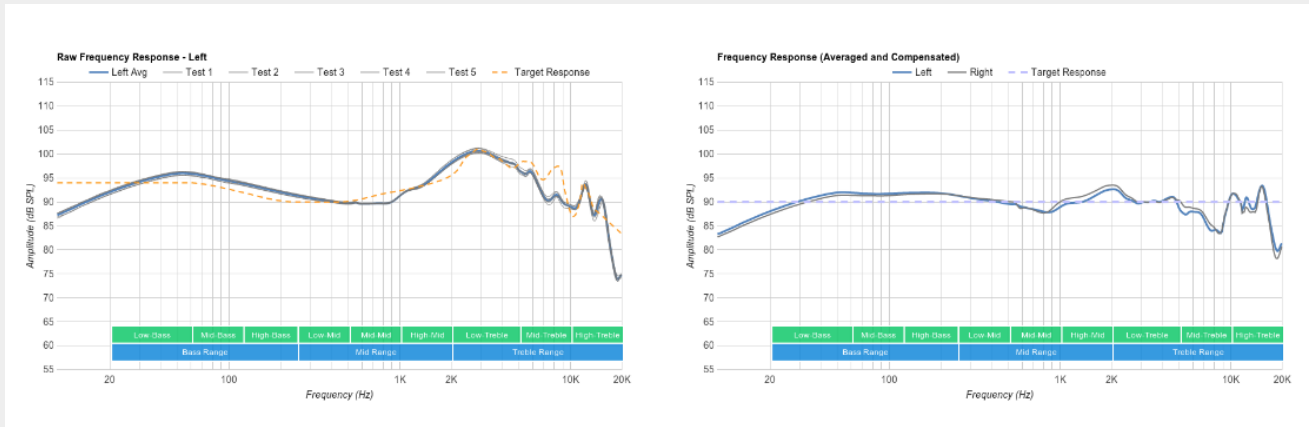

Target compensated

## HD600

### Sennheiser HD600

- <https://www.rtings.com/>
- <https://www.rtings.com/headphones/tests/sound-quality/raw-frequency-response>

Rtings Target Target curve  
diffuse field target

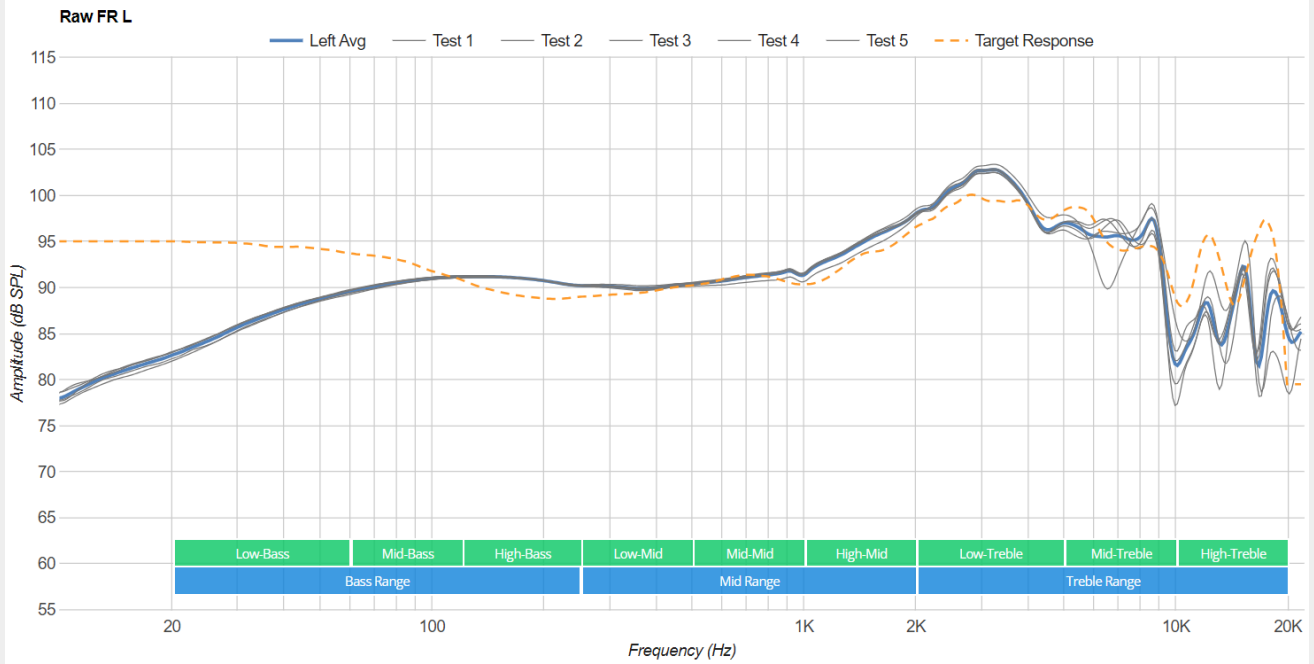

Raw Frequency Response,

RAW

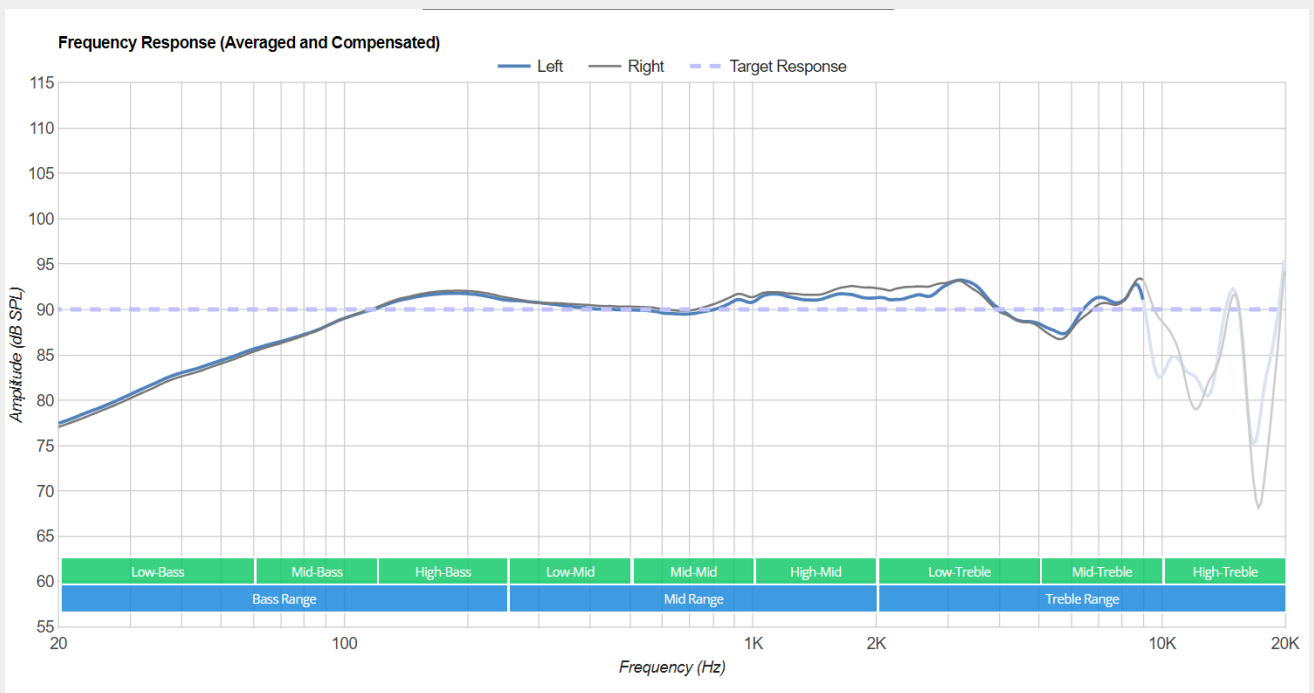

Target Compensated Frequency Response, Target

가

RAW

# Reference

- <https://audioxpress.com/article/electroacoustic-measurements-of-headphones>
- <https://www.rtings.com/headphones/tests/sound-quality/raw-frequency-response>





<http://wiki.homerecz.com>

From:

<https://wiki.homerecz.com/> -

Last update: **2024/12/29**

: (admin@homerecz.com)