



<http://wiki.homerecz.com>



..... 1

..... 1

..... 1

..... 1

( ) ..... 5

..... 7

..... 9

..... 9

..... 9

..... 11

/ ..... 13

..... 15

..... 15

..... 15

..... 15



( )

가 . . . 1)( , 16 , 16 / )

DAW

가

가

가

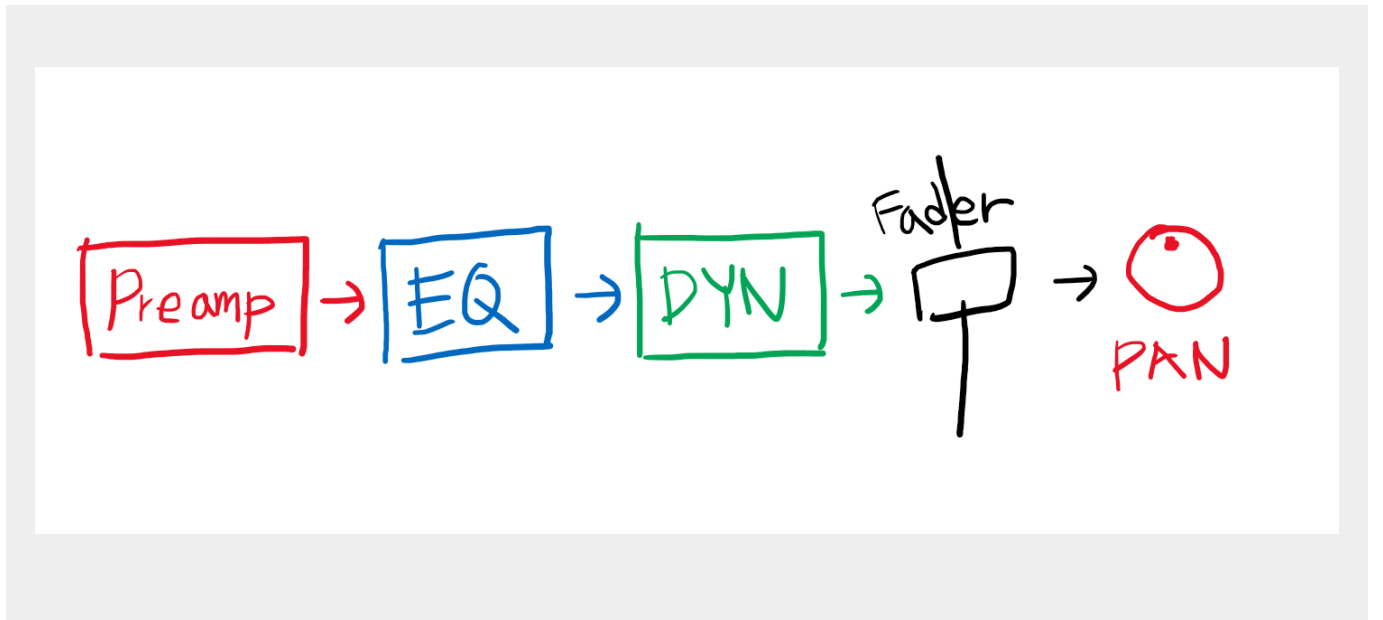



Waves SSL EV1

### Input Channel Signal Flow

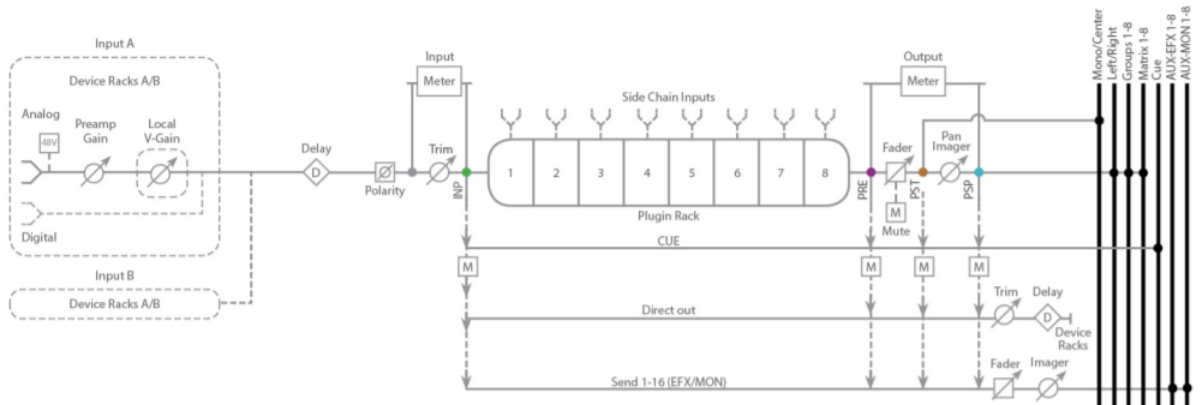

### Waves LV1

LV1

가

,

“ **Focus**

**Focal length**

2)

3)



Neve 1073

- 
- [AMEK 9098 dual mic pre](#)
- [AMEK 9098 Mic Pre with EQ](#)
- [AMEK M2500 MIC Pre](#)
- [Ampex 351](#)
- [API 312](#)
- [API 512c](#)
- [API 512v](#)
- [Clarett+ Octopre](#)
- [Focusrite Clarett OctoPre](#)
- [Focusrite Green 1](#)
- [Focusrite ISA One](#)
- [Focusrite ISA Two](#)
- [Focusrite ISA110](#)
- [Focusrite ISA220 Session Pack](#)
- [Focusrite ISA428](#)
- [Focusrite ISA428 MkII](#)
- [Focusrite ISA828](#)
- [Focusrite ISA828 MkII](#)
- [Focusrite Liquid 4 Pre](#)
- [Focusrite Octopre mk2](#)

- [Focusrite Octopre mk2 Dynamic](#)
- [Focusrite Octopre Platinum](#)
- [Focusrite Octopre Platinum LE](#)
- [Focusrite Platinum Tone Factory](#)
- [Focusrite RED 1](#)
- [Focusrite RED 1 500](#)
- [Focusrite Scarlett OctoPre](#)
- [Focusrite Scarlett OctoPre Dynamic](#)
- [Grace Design M108](#)
- [Grace Design M801](#)
- [Harrison 32Cpre+](#)
- [M-Audio Octane](#)
- [Magic Death Eye](#)
- [Neve 88RLB](#)
- [Neve 1064](#)
- [Neve 1066](#)
- [Neve 1073](#)
- [Neve 1081](#)
- [Neve 1081R](#)
- [Neve 1084](#)
- [Neve 31102c](#)
- [Neve 31104](#)
- [Neve 31105](#)
- [RME 12Mic](#)
- [RME Micstasy](#)
- [RME Octamic II](#)
- [RME OctaMic XTC](#)
- [RME Quad Mic](#)
- [RND Portico 5012](#)
- [SSL PureDrive Octo](#)
- [SSL4000E Input preamp](#)
- [Telefunken V72](#)
- [Telefunken V76](#)
- [TUBE-TECH MP1A](#)
- [TUBE-TECH MP2A](#)
- [Universal Audio 4-710d](#)
- [Universal Audio 610 Tube Preamp](#)
- [Universal Audio 710 Twin-Finity](#)
- [Universal Audio 4110](#)
- [Universal Audio 8110](#)
- [Universal Audio Solo 110](#)

---

...



가

- 
- 
- 
- 

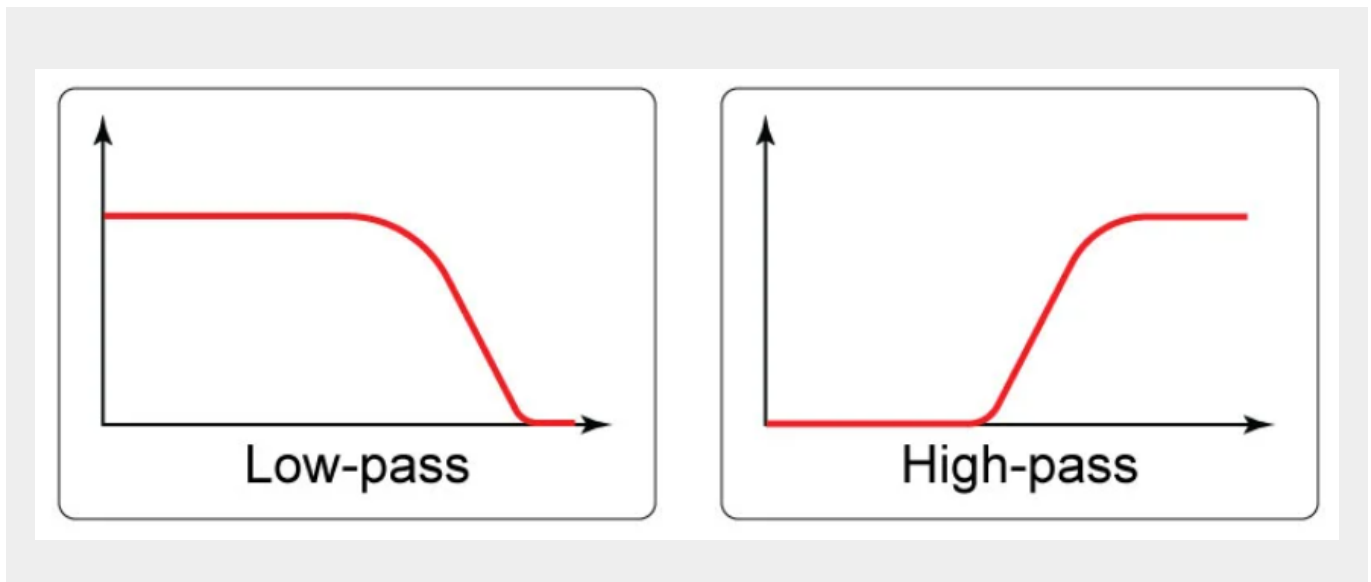

...



가

600Ω  
가



- 
- Focusrite Blue 315 MKII
- Focusrite Red 2
- Manley Massive Passive
- Pultec EQP-1
- Pultec HLF3
- Pultec MEQ5
- TUBE-TECH PE1C
- 
- 
- 
- 
- 

...

### Compressor

FM

가

8dB

4)



- 
- [Abbeyroad RS124](#)
- [Altec 436B](#)
- [Altec 436C](#)
- [API 2500](#)
- [dbx 160](#)
- [dbx 165](#)
- [Empirical Labs Distressor](#)
- [Eventide Omnipressor](#)
- [Fairchild 660/670](#)
- [Focusrite Blue 330](#)
- [Focusrite Platinum Compounder](#)
- [Focusrite Platinum Penta](#)
- [Focusrite RED 3](#)
- [Focusrite RED 8](#)
- [Neve 2252](#)
- [Neve 2254](#)
- [Neve 33609](#)
- [Neve 33611](#)
- [RCA BA-6A](#)
- [SSL FX G384](#)
- [SSL G-comp](#)
- [SSL The Bus+](#)
- [SSL4000E LMC\(ListenMic Compressor\)](#)
- [Telefunken U73](#)
- [Teletronix LA-2A](#)

- [TUBE-TECH CL 1B](#)
- [UREI 1176 Peak limiter](#)



...

/

(Gate) (Expander)

1. **(Gate):**

가

2. **(Expander):**

가

...

1)

2)

by

3)

- :
- :
- :

4)

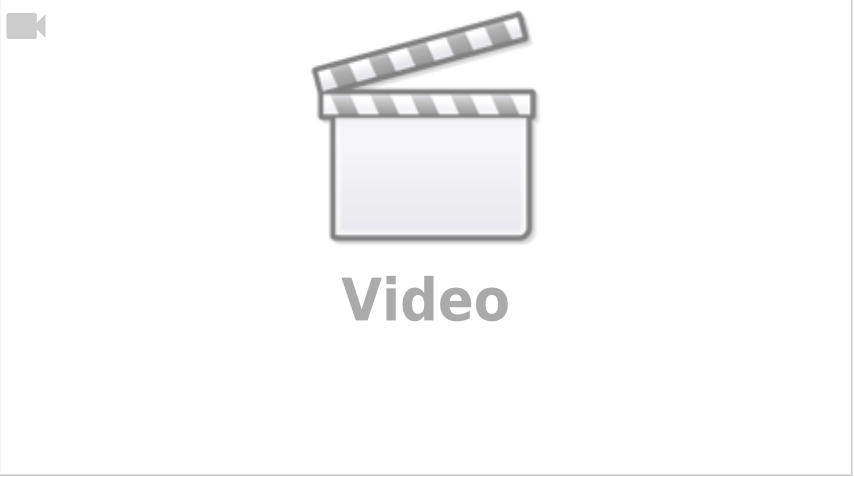



<http://wiki.homerecz.com>

From:

<https://wiki.homerecz.com/> -

Last update: **2025/02/16**

: (admin@homerecz.com)