



<http://wiki.homerecz.com>

..... 1

..... 1

..... 1

..... 1

..... 5

..... 5

..... 5

..... 5

..... 5

..... 5

..... 6

..... 6

..... 7

..... 7

..... 8

..... 9

..... 9

The Bass Loss Problem 9

Reference 10

..... 11

..... 11

..... 11

..... 11

Inverse Square Law

가 2 가 1) , 가 .
 가 2 가 (dBSPL) , 가 2 6dB (1/4) ,
 가 2 가 6dB(4) 가 . 2)
 , ,

Point source

가 2 (Spherical wave form) 가 .
 가 2 6dB .

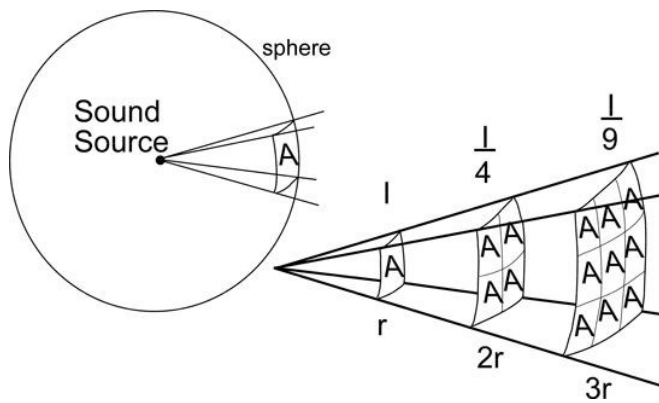

가 .

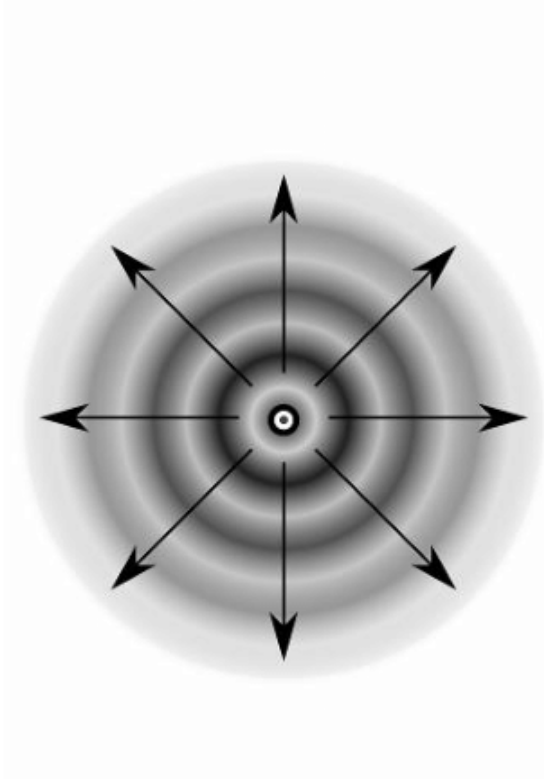

Point source

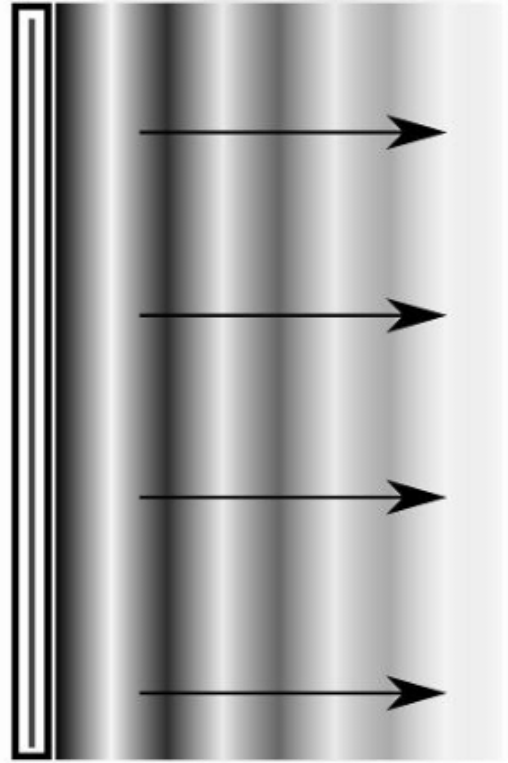

Plane source

Line Source

가

가 a

$$\frac{\alpha}{\pi}$$

가 2

-3dB

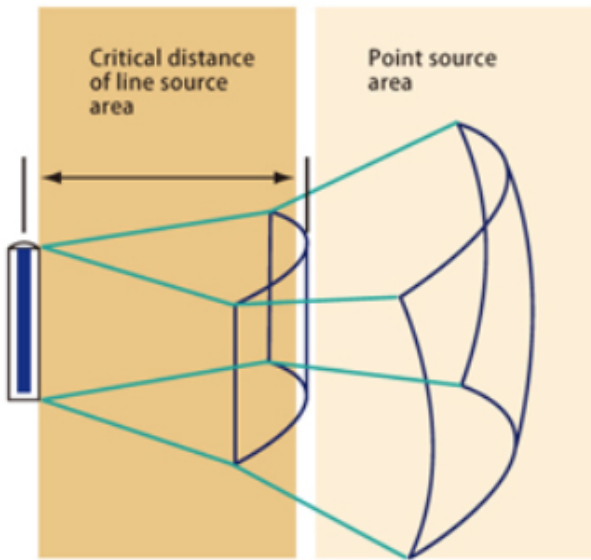

$\frac{a}{\pi}$, 가 2
 -6dB .

Plane Source

가 . (Plane wave form) 가 .

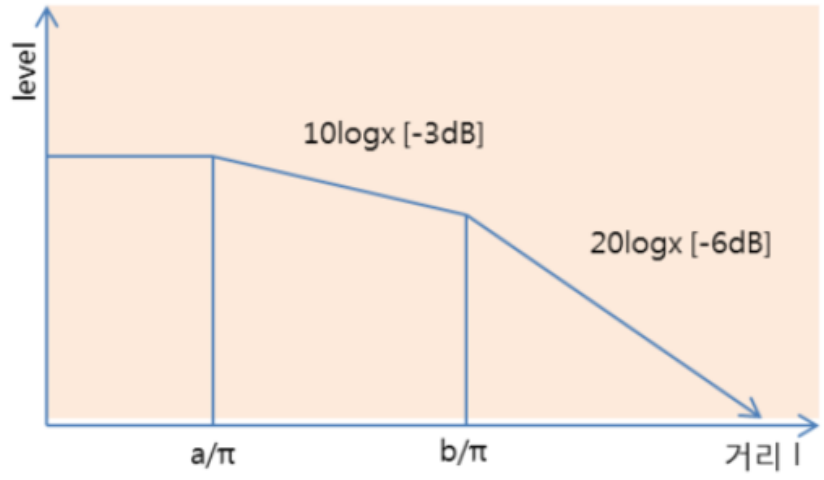
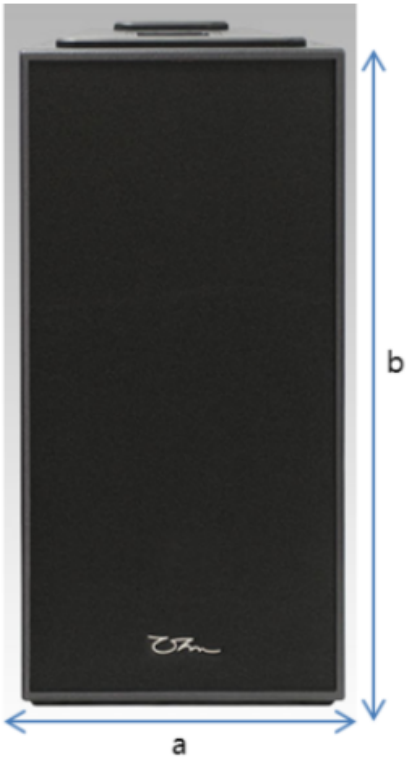

$\frac{a}{\pi}$ $\frac{b}{\pi}$ $\frac{a}{\pi}$
 가 가 , 가 2 -3dB ,
 가 , 가 2 -6dB ,
 가 , 가 .

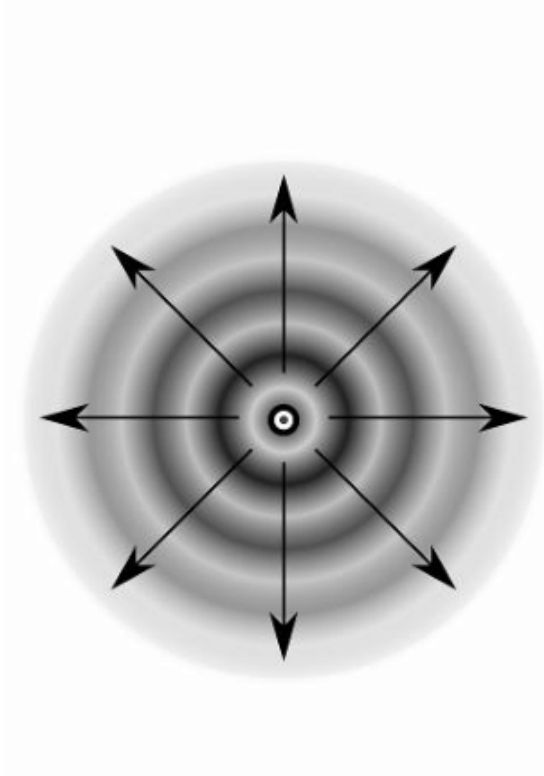

Point source

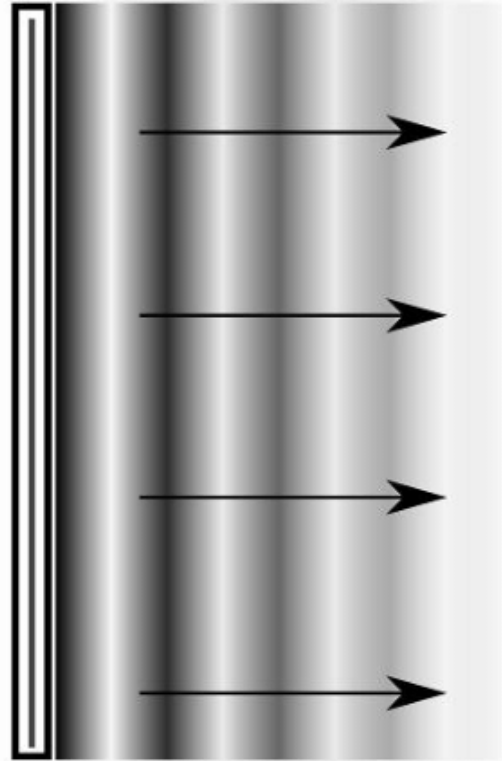

Plane source

가

가

Assume that the close listener hears both the low bass at 30 Hz and the midrange frequency 2000 Hz at the same loudness of 80 phons. Because of the difference in hearing sensitivity, the dB levels required are

30 Hz, 103 dB, 80 phons
2000 Hz, 76 dB, 80 phons

By the inverse square law, each of these levels will drop by 20 dB at 200 ft.

Although the dB levels of the two sounds will drop by the same amount, the loudness of the low frequency drops more than that of the high frequency because of the ear's discrimination against bass.

30 Hz, 83 dB, 50 phons
2000 Hz, 56 dB, 60 phons

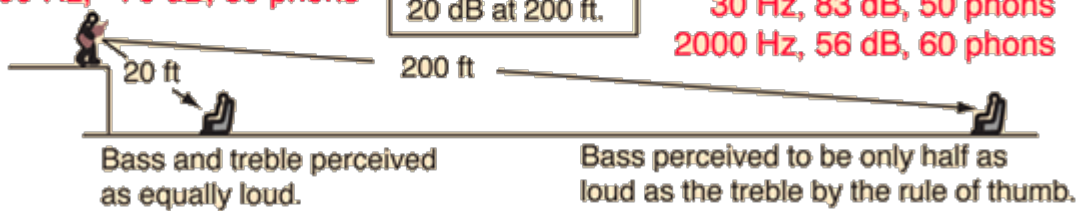

The Bass Loss Problem

When sound drops off according to the inverse square law, the sound further from the source is not

only perceived as less loud but also as deficient in the bass frequencies. This is a natural result of the human hearing response as revealed by the equal loudness curves. There is a bass discrimination in the human hearing response for soft sounds.

Reference

- <http://hyperphysics.phy-astr.gsu.edu/>

1)

2)

dBSPL 2 가 3dB 가, 2 3dB .

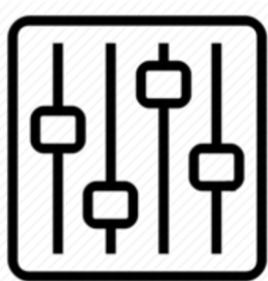

<http://wiki.homerecz.com>

From:

<https://wiki.homerecz.com/> -

Last update: **2023/04/18**

: (admin@homerecz.com)